

Vegetable Slicer TRS Vegetable Slicer - Variable Speed

ITEM # _____

MODEL # _____

NAME # _____

SIS # _____

AIA # _____

600473 (TRSYVVI)

Vegetable Slicer, variable speed 140 to 750 rpm, 500 W. Lever operated hopper in stainless steel for intense use (CB certification) - Schuko plug

Short Form Specification

Item No.

Universal vegetable slicer for more than 80 different types of cuts, thanks to several stainless steel dw safe discs.

Parts in contact with food - stainless steel lever, stainless steel hopper and cutting chamber - can be removed without tools and placed in a dishwasher for fast cleaning.

Compact and ergonomic design, user-friendly lever (better pressure control, with less effort for arms and shoulder), designed for right and left handed users.

Angled base (20°) facilitates loading and unloading operations. Long vegetable hopper (55,5mm diameter), integrated in the wide 3/4 moon round hopper (215cm²) in stainless steel. Asynchronous industrial motor for heavy duty and longer life. High discharge zone (up to 20cm) for GN containers. Variable speed (140 to 750 rpm) and pulse control for precise slicing. Automatic start/stop function will stop the machine when the lever hopper is lifted and will restart automatically when lowered. Waterproof control panel and aluminium alloy motor base completely closed for complete protection against strong jets of water.

Main Features

- Suitable for 100-400 meals for table service and up to 800 meals for catering service.
- Vegetable slicer with slicing, grating, shredding (julienne) as well as dicing and French fries cutting capability.
- Ergonomically designed for right and left-handed users, frontal working and to reduce working space around the machine.
- All parts in contact with food are removable without the use of tools, stainless steel hopper, stainless steel lever and cutting chamber are dishwasher safe.
- Hopper easily removed for cleaning.
- High discharge zone permits the use of deep GN containers (up to 20cm).
- Complete and wide selection of blades and grids available (diam. 205 mm).
- Pulse function for precise cutting.
- Magnetic safety system and motor brake. Prevents machine from running when lever swings away or is open.
- Automatic restart of the machine with the 3/4 moon shaped pusher in position.
- Continuous feed model.
- Base inclined at 20° to provide easy loading and unloading.
- Red OFF, green ON buttons.
- Delivered with:
 - All stainless steel vegetable prep attachment with a lever-integrated long vegetable hopper (55,5mm diameter) and a large round hopper (215cm²)

Construction

- All blades (available on request) are made in stainless steel and dishwasher safe.
- Compact and portable design.
- Asynchronous silent industrial motor for heavy duty and longer life.
- Feeding arm and hopper are made entirely in stainless steel. Aluminum motor housing.
- Improved ventilation system to manage smoothly heavy duty use.
- Reinforced basement and feet to withstand the continuous movements of the unit.
- Improved fixing of long vegetable hopper pusher.
- Main on/off switch for added safety.
- Power: 500 Watts.
- Variable speed (140 to 750 rpm).
- Main switch ON/OFF on the back of the appliance.

Included Accessories

- 1 of Ejector disc for vegetable slicer TRS/TRK/TR210 PNC 653772

Optional Accessories

- Stainless steel shredding disc with S-blades 4x4 mm PNC 650077

APPROVAL: _____

• Stainless steel shredding disc with S-blades 6x6 mm (can also be used for French fries)	PNC 650078	<input type="checkbox"/>	• Set of 7 discs (2mm, 5mm and 10mm slicing pressing discs, 2mm and 7mm grating discs, 4x4mm shredding disc, 10x10mm dicing grid) and grid cleaning tool	PNC 650114	<input type="checkbox"/>
• Stainless steel shredding disc with S-blades 8x8 mm (can also be used for French fries)	PNC 650079	<input type="checkbox"/>	• Aluminum pressing/slicing disc with straight blades 10 mm - for dicing	PNC 650115	<input type="checkbox"/>
• Stainless steel shredding disc with S-blades 10x10 mm (can also be used for French fries)	PNC 650080	<input type="checkbox"/>	• Aluminum pressing/slicing disc with straight blades 8 mm - for dicing	PNC 650116	<input type="checkbox"/>
• Stainless steel pressing/slicing disc with S-blades 0,6 mm (can be used for slicing or combined with grids)	PNC 650081	<input type="checkbox"/>	• Stainless steel shredding disc with S-blades 2x8 mm	PNC 650158	<input type="checkbox"/>
• Stainless steel pressing/slicing disc with S-blades 1 mm (can be used for slicing or combined with grids)	PNC 650082	<input type="checkbox"/>	• Stainless steel shredding disc with S-blades 2x10 mm	PNC 650159	<input type="checkbox"/>
• Stainless steel pressing/slicing disc with S-blades 2 mm (can be used for slicing or combined with grids)	PNC 650083	<input type="checkbox"/>	• Stainless steel pressing/slicing disc with S-blades 10 mm (can be used for slicing or combined with grids)	PNC 650160	<input type="checkbox"/>
• Stainless steel pressing/slicing disc with S-blades 3 mm (can be used for slicing or combined with grids)	PNC 650084	<input type="checkbox"/>	• Stainless steel pressing/slicing disc with S-blades 12 mm (can be used for slicing or combined with grids)	PNC 650161	<input type="checkbox"/>
• Stainless steel pressing/slicing disc with S-blades 4 mm (can be used for slicing or combined with grids)	PNC 650085	<input type="checkbox"/>	• Stainless steel pressing/slicing disc with corrugated S-blades 8 mm (can be used for slicing or combined with grids)	PNC 650162	<input type="checkbox"/>
• Stainless steel pressing/slicing disc with S-blades 5 mm (can be used for slicing or combined with grids)	PNC 650086	<input type="checkbox"/>	• Stainless steel pressing/slicing disc with corrugated S-blades 10 mm (can be used for slicing or combined with grids)	PNC 650164	<input type="checkbox"/>
• Stainless steel pressing/slicing disc with S-blades 6 mm (can be used for slicing or combined with grids)	PNC 650087	<input type="checkbox"/>	• Stainless steel pressing/slicing disc with S-blades 13 mm (can be used for slicing or combined with grids)	PNC 650165	<input type="checkbox"/>
• Stainless steel pressing/slicing disc with S-blades 8 mm (can be used for slicing or combined with grids)	PNC 650088	<input type="checkbox"/>	• Stainless steel shredding disc with S-blades 2x2 mm	PNC 650166	<input type="checkbox"/>
• Stainless steel pressing/slicing disc with corrugated S-blades 2 mm (can be used for slicing or combined with grids)	PNC 650089	<input type="checkbox"/>	• Stainless steel shredding disc with S-blades 3x3 mm	PNC 650167	<input type="checkbox"/>
• Stainless steel pressing/slicing disc with corrugated S-blades 3 mm (can be used for slicing or combined with grids)	PNC 650090	<input type="checkbox"/>	• Set of 4 stainless steel discs (2mm and 5mm slicing pressing discs, 2mm and 7mm grating discs)	PNC 650178	<input type="checkbox"/>
• Stainless steel pressing/slicing disc with corrugated S-blades 6 mm (can be used for slicing or combined with grids)	PNC 650091	<input type="checkbox"/>	• Stainless steel work table with folding shelves and disk rack for TRK and TRS table top models	PNC 653283	<input type="checkbox"/>
• Bistrot Pack-set stainless steel discs (2mm and 5mm slicing pressing disc, 2mm grating disc)	PNC 650092	<input type="checkbox"/>	• Dicing grid 5x5 mm	PNC 653566	<input type="checkbox"/>
• Set of 3 stainless steel discs for Pizza (2mm and 4mm pressing/slicing discs with S-blades, 7mm grating disc)	PNC 650107	<input type="checkbox"/>	• Dicing grid 8x8 mm	PNC 653567	<input type="checkbox"/>
• Cleaning tool for 5-8-10 mm dicing grids	PNC 650110	<input type="checkbox"/>	• Dicing grid 10x10 mm	PNC 653568	<input type="checkbox"/>
• Dicing kit 10x10x10mm, diam. 205mm (10mm aluminum slicing pressing disc, 10mm grid and grid cleaning tool)	PNC 650112	<input type="checkbox"/>	• Dicing grid 12x12 mm	PNC 653569	<input type="checkbox"/>
• Gastronomy Pack-set discs (2mm, 5mm and 10mm slicing pressing discs, 2mm grating disc, 4x4mm shredding disc, 10x10mm dicing grid) and grid cleaning tool	PNC 650113	<input type="checkbox"/>	• Dicing grid 20x20 mm	PNC 653570	<input type="checkbox"/>
			• Grid for chips 6x6 mm	PNC 653571	<input type="checkbox"/>
			• Grid for chips 8x8 mm	PNC 653572	<input type="checkbox"/>
			• Grid for chips 10x10 mm	PNC 653573	<input type="checkbox"/>
			• Support for 1 disc, diam. 175mm and 205mm	PNC 653632	<input type="checkbox"/>
			• Ejector disc for vegetable slicer TRS/TRK/TR210	PNC 653772	<input type="checkbox"/>
			• Stainless steel grating disc 2 mm	PNC 653773	<input type="checkbox"/>
			• Stainless steel grating disc 3 mm	PNC 653774	<input type="checkbox"/>
			• Stainless steel grating disc 4 mm	PNC 653775	<input type="checkbox"/>
			• Stainless steel grating disc 7 mm	PNC 653776	<input type="checkbox"/>
			• Stainless steel grating disc 9 mm	PNC 653777	<input type="checkbox"/>
			• Stainless steel grating disc for knoedeln and bread	PNC 653778	<input type="checkbox"/>
			• Stainless steel grating disc for parmesan and bread	PNC 653779	<input type="checkbox"/>

Front

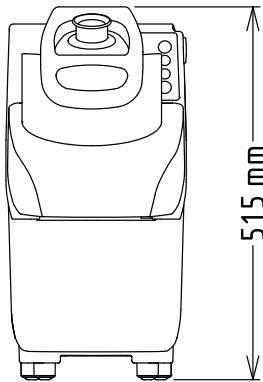

Side

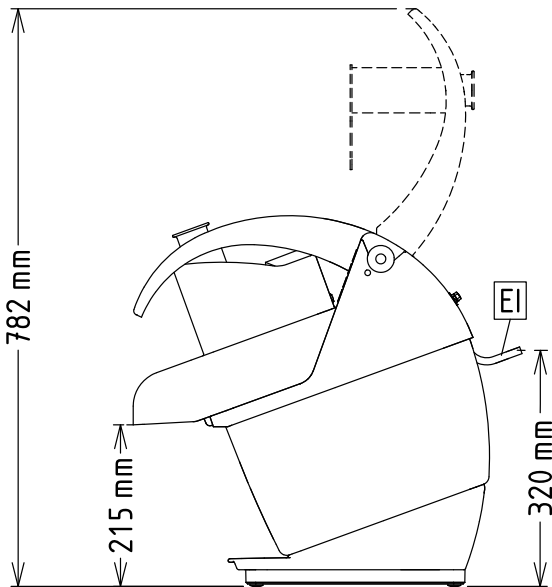

EI = Electrical inlet (power)

Top

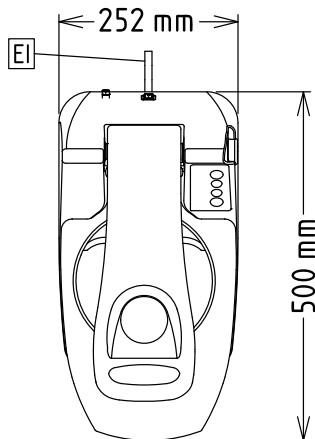
Electric

Supply voltage:	200-240 V/1N ph/50/60 Hz
Electrical power, max:	0.5 kW
Total Watts:	0.5 kW

Capacity:

Performance (up to):	550 kg/Cycle
----------------------	--------------

Key Information:

External dimensions, Width:	252 mm
External dimensions, Depth:	500 mm
External dimensions, Height:	515 mm
Shipping weight:	23 kg